

Ultima VII[®] SERPENT ISLE[™]
PART TWO

THE SILVER SEED[™]

TABLE OF CONTENTS

PLAY GUIDE	7
GARRISON	9
DARK MONKS	9
SERISS: THE ORDER KEEP	10
SOLUTION	11
BASIC QUEST	11
SERISS: THE KEEP	12
DARK MONKS	12
ABANDONED OUTPOST	14
ARAM-DOL'S LAIR	16
FIEND'S DOMAIN	18
MAGIC ORBS	19
THE SILVER SEED	19
OTHER MAGIC ITEMS	19
MAGIC ITEMS	20
HOT KEYS	20
TECHNICAL SUPPORT	21
LIMITED WARRANTY	22
MEDIA REPLACEMENT	22
CREDITS	22

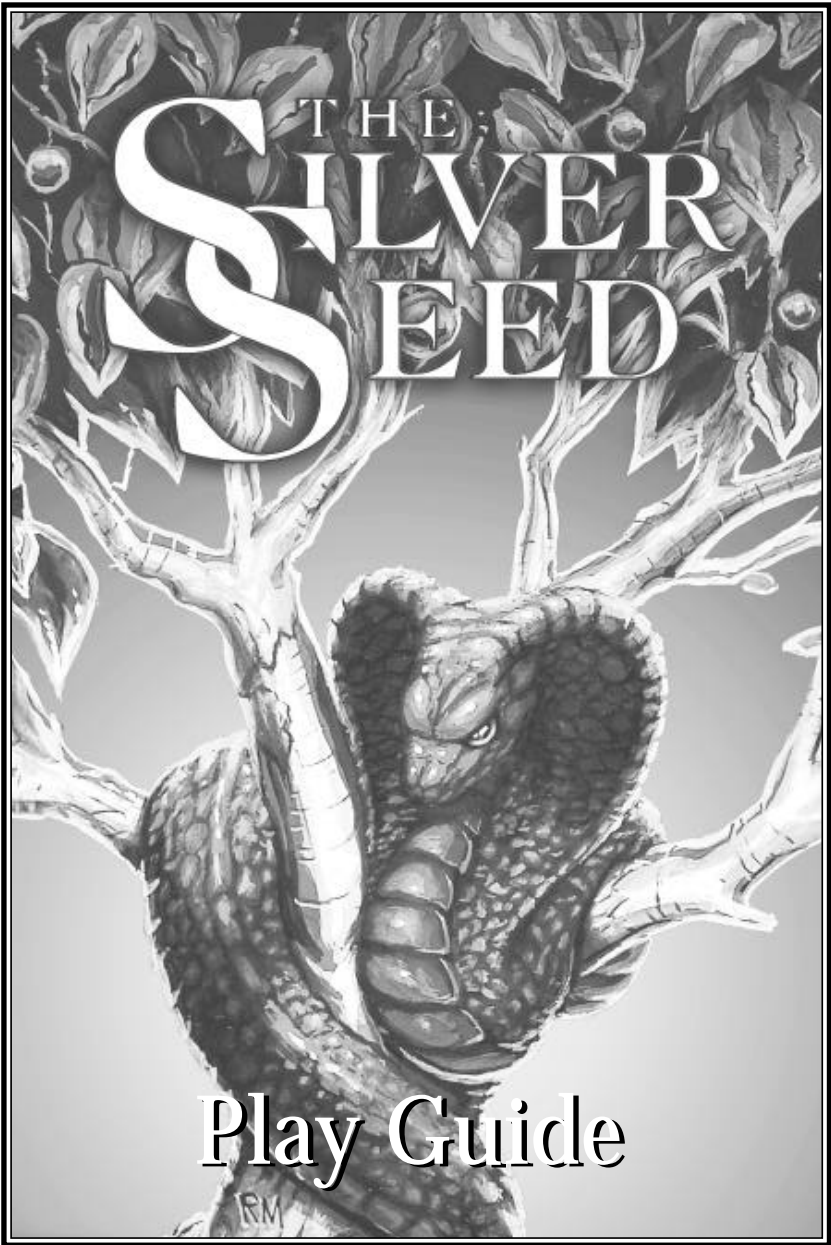

English





Revered Order Hierophant,

It is my pleasure to present to thee the first report concerning my new duty station. I include a map of the keep to familiarize thee with Seriss and its particulars. My arrival has caused some agitation in the garrison — but I prepared for that. I can assure thee that I have the situation completely under control. The warriors must learn to obey my orders and pay me the respect that I deserve as the Commander of the Order Forces at this post. In time, they will discover the importance of Ethicality and Discipline, certis. To the best of my ability I will instruct them more deeply in the virtues and aid them with their internal conflicts. It honors me that my superiors have entrusted me with this position. I am dedicated to carrying out my orders and will meet all expectations to perfection — as always.

Yours faithfully,
I sstanar



GARRISON

There are only three Order warriors left in this command. Since most of the labor is performed by automatons, there is little for the human warriors to do around the keep. All of them are eager for news about the battle that is raging at the front. Being the new Commander of this post, I am their only source of information. They generally stay in their rooms and invent new trivialities to overcome the monotony in their lives. However, I must admit that they work fairly well together.

Tsander is now Subcommander of this outpost. My arrival seems to have upset him and made him jealous. I believe he blames me for his demotion. He often discusses and praises his former commander, Ardiniss, when I am not around. I anticipate difficulties with this warrior.

Elissa is the Mage at this outpost, giving her rank equal to that of Tsandar. She considers the benefits of eternal life as an Order Automaton more and more often. I believe she admires me. Perhaps, in time, she will be worthy to make the ultimate sacrifice.

Surok is the Healer of the keep. He is much older than his companions and seems weary of the discipline expected of him. I assume that seeing his friends die over the last several hard years has made him bitter. He does not seem comfortable around me, which probably has to do with my appearance. I hope to re-instill a sense of duty in him soon.

DARK MONKS

Occasionally I overhear conversations between the warriors here in Seriss. They often mention the names of three sorceresses, members of the Dark Monks — Rieya, Solaria and Drusilla. From the information available to me at this point, I must assume that these monks have great power.

They are not fond of the Order Forces; they believe in their own distinct prophecies. These monks speak some drivel about destroying the “Pawn of Prophecy.” They believe their victim will arrive here through the powers of the Amulet of Balance. I don’t know what to make of all their prattle. I don’t think they are talking about our hero, the Champion of Balance. If he ever arrives here, I will give him the magic Key Ring as I have been ordered by thee, Calithiss, revered Order Hierophant.

The three monks haven’t caused the keep any trouble so far; therefore, I shall allow them to remain in this area. Although I don’t trust them under any circumstances, a treaty has been signed — they may each stay at the entrance of a different dungeon, as long as they repulse any interlopers seeking that route into Seriss. I haven’t been here long enough to know them well, but I plan on gathering more material for my next report to thee. You will find a key on each Dark Monk. These keys open the doors leading to the glade where you must plant the Silver Seed.

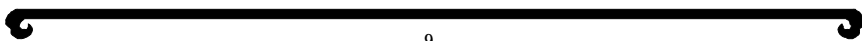



SERISS: THE ORDER KEEP

- 1) Drawbridge
- 2) Courtyard
- 3) Serpent Gate
- 4) Smithy
- 5) Barracks
- 6) Great Hall
- 7) Laboratory
- 8) Armory
- 9) Library
- 10) Jail
- 11) Back path to Aram-Dol's lair
- 12) Path to chasm
- 13) Chasm with draw-bridge

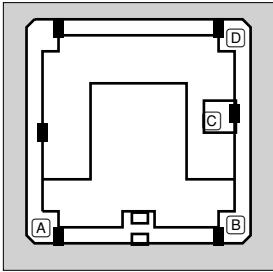

Parapet

Ground Level

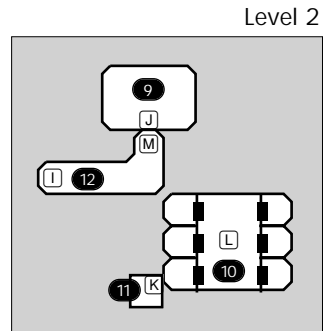
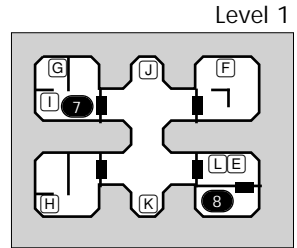
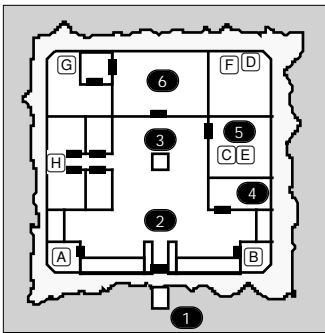

Note: In this, and in all other maps, letters in round-cornered boxes (A, B, C and so forth) indicate the two ends of a stairwell. For example, on the map of the keep, A marks a stairwell that leads from the ground level up to a corner of the parapet.

Dangerous dungeons surround the keep. Some were once part of the keep and became what they are now after being abandoned. Other dungeons belonged to the Forces of Chaos. I have heard rumors of gruesome creatures in all of these areas.

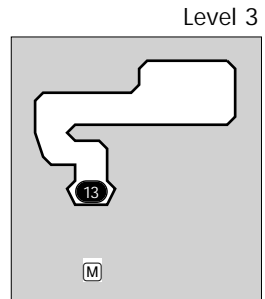



SOLUTION

Use the titles to find the section of this walkthrough that you're looking for. If you want just a vague, sometimes cryptic hint, read only the bold-face introductory sentence. For full details, read the rest of the section. Material in parentheses at the end of the section provides interesting information that is not necessary to solve *The Silver Seed*.

WARNING:

Reading this solution will reveal all important clues and may spoil the fun of solving the game on your own. Read the following *only* if you need help to advance in the game!



Basic Quest

You must obtain four Magic Orbs to get the Silver Seed and save Serpent Isle from destruction. (For more information, see Magic Orbs and notes on specific areas in the solution.)

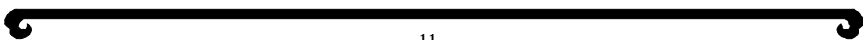



SERISS: THE KEEP

Find and talk to Isstanar.

Get the magic Key Ring from him. Each passageway out of the keep represents one quest. Each quest is an opportunity for you to acquire a powerful weapon or a magic item. The entrances can be found by exploring the city or talking to the warriors. Surok the healer will resurrect you, if you are killed during the game. He will assist you in any way he can.

(Isstanar has switched bodies with an automaton. He demands total obedience from his subordinates.)

DARK MONKS

Don't trust everything the Dark Monks tell you.

The three Dark Monks are powerful sorceresses and believe that they must destroy you after your arrival. They will give you hints at the entrances of the dungeons. You can only trust Drusilla. You must kill the Dark Monks in the final scene. Once the Dark Monks are dead, any transformed companions will be restored to their proper forms.

(The sorceresses do not get along well.)



MAZE

Cheese, cats and (of course) dead bodies are the crucial points here.

You can trust Drusilla and her information. She is the only Dark Monk who doesn't lie to you. Your companions refuse to enter the maze, and when you enter, everything in your inventory disappears until you leave again. You can find cheese on a dead body within the maze. Find the Chaos "monster" Yurel. He has the Purple Orb and will trade it for cheese. The Helm of Light is on Issik's body. You will be able to reclaim your inventory once you have exited the maze.

(This place was originally designed as a storehouse for the treasures of Order.)





Maze

- 1) Entrance
 - 2) Dead body
 - 3) Yurel's chamber
 - 4) Issik, the dead architect
 - 5) Exit
- T1-6)Teleport pads

Maze 1

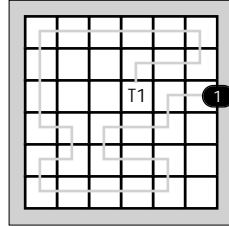

Maze 2

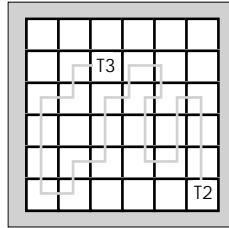

Maze 3

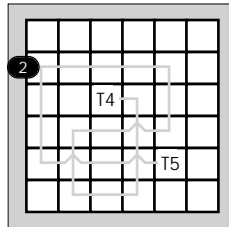

Maze 4

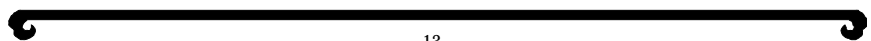
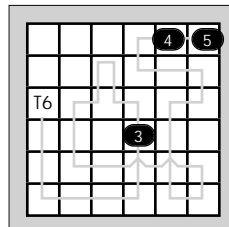



ABANDONED OUTPOST

Explore the area and search dead bodies for useful items.

English

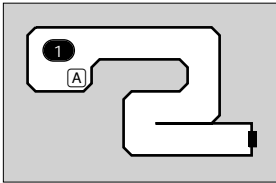

Level 1

Don't give up if you can't open some of the doors — if they're illusionary, you can just walk through them.

The forcewalls at (5) can be removed by pressing three buttons in this order: upper right, upper left, lower left (oriented according to the map).

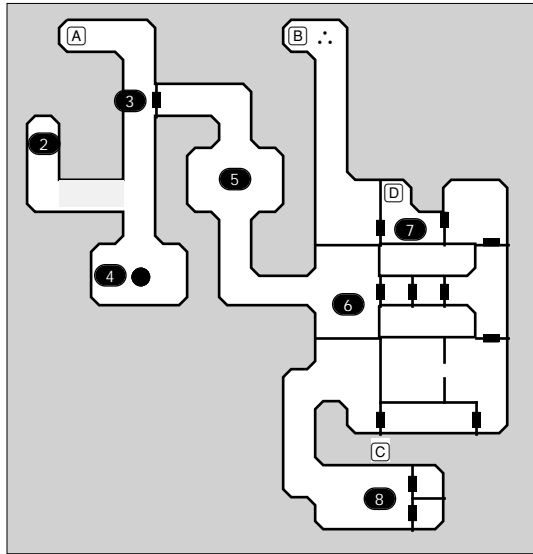

Level 2

Level 3

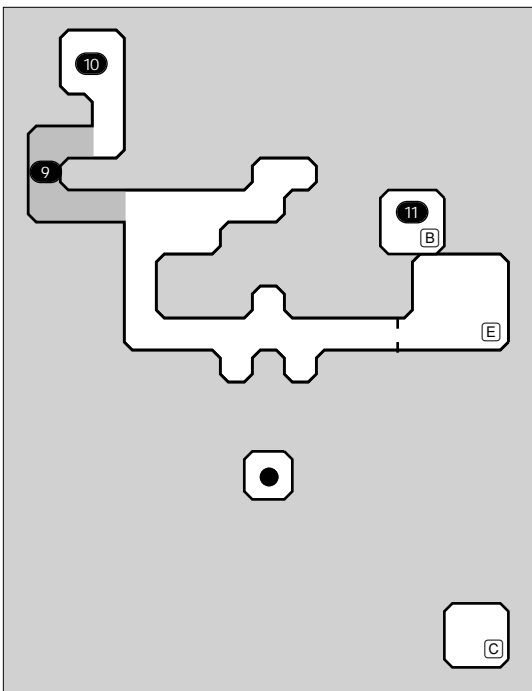

Check the bodies for useful supplies of all sorts. Place the lightning whip on the platform at (7) to get down the stairs. Once you get down stairwell [E], go through the doorway, kill the animated armour, then press the plates in the alcoves in reverse order: third, second, first. (The plates must be in their original positions before the trap is disarmed: the first one up, the second down and the third up.) This dispels the sleep fields (9) leading to the Red Orb.

In the torture chamber (8), find a secret passage (in the iron maiden) and a magic scroll (in the left-hand cell). The secret passage





leads to several powderkegs, which will prove useful in clearing the way to stairwell [B]. Reading the magic scroll outside the forcewalls at the bottom of the well destroys them.

A coil of rope is on the body at (10). Use the rope on the brass well to lower yourself all the way down, recite the magic scroll (8) by the forcewalls, then climb down the stairs at [H]. Defeat the ice elementals and retrieve the Belt of Strength from near the treasure pile.

(Loriel made this belt for her husband, out of woven hair from Giants, and enchanted it to give the bearer great strength.)

Abandoned Outpost

- 1) Entrance
 - 2) Lever to open secret door (3)
 - 3) Secret door
 - 4) Brass well
 - 5) Force walls and buttons
 - 6) Dead bodies
 - 7) Stairs to fourth level
 - 8) Torture chamber
 - 9) Sleep fields
 - 10) Red Orb
 - 11) Dead body
 - 12) Treasure pile
- ∴ Rubble blocking path
- Illusionary wall

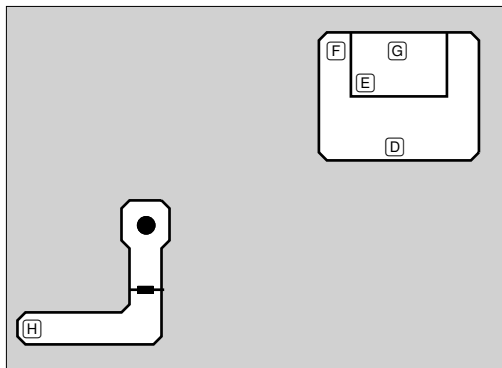

Level 4

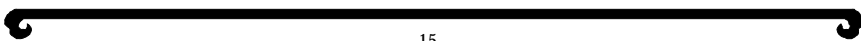
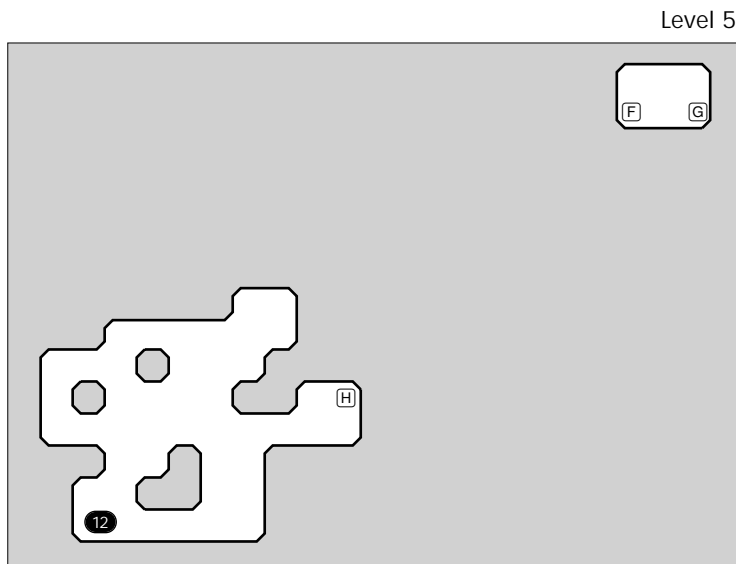



ARAM-DOL'S LAIR

Be prepared to fight a lot. Look out for illusionary walls and passageways, and read the plaques carefully. Solve the lever puzzles to proceed.

It isn't necessary to kill Draxinar (the dragon). In fact, it is much better not to. Draxinar tells riddles and gives information.

After teleporting to (6), the key hidden behind a pedestal can unlock the door to stair

L. This stair leads down to a lever that you must pull to open the secret door at (9). (However, this secret door hides nothing useful.)

Aram-Dol's Lair

- 1) Entrance
 - 2) Stairs to Draxinar's lair
 - 3) Draxinar's lair
 - 4) Main cavern of the Arachnians
 - 5) Teleporter to (6)
 - 6) Teleporter from (5)
 - 7) Lever rooms
 - 8) Crypts
 - 9) Looping passages
 - 10) Skeletal dragon
 - 11) Hallway
 - 12) Aram-Dol's room
 - 13) Treasure room
 - 14) Back path to the Keep
- ∴ Rubble blocking path
 Illusionary wall

Level 1

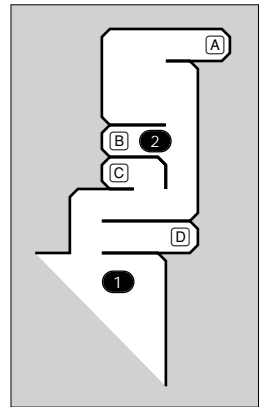

Level 2

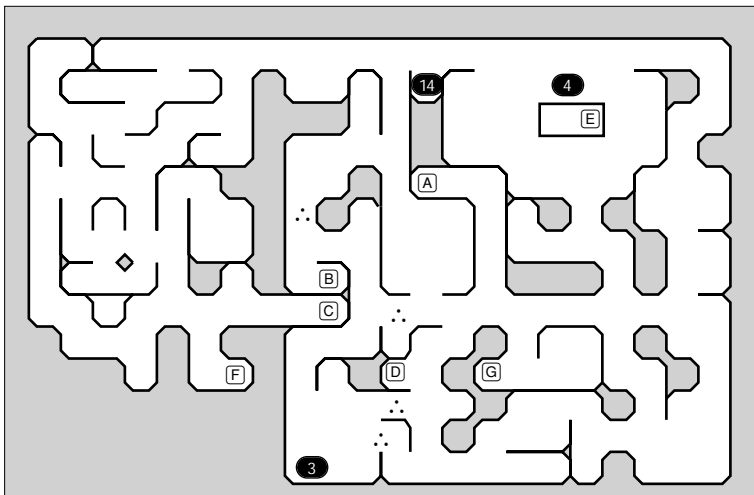



There are several rooms in a row with levers that you must traverse (7). The first room bears the runic legend: "Guess right or die!" For the first set of three levers ("Throw two down"), pull only the second lever. At the next set of five levers ("three will get you eight"), pull levers 1, 2 and 5. At the third set of seven levers ("throw four to get twelve"), pull levers 1, 2, 3 and 6.

Along the hallway (11), you must pull the switch in each room. After pulling all ten switches, you must pull the brass lever and the door at the end of the hallway will be unlocked.

Destroy Aram-Dol. Use the key off his dead body to unlock the nearby treasure room. The Gloves of Karas the Quick, Erinon's Axe and the Blue Orb are in that room.

Level 3

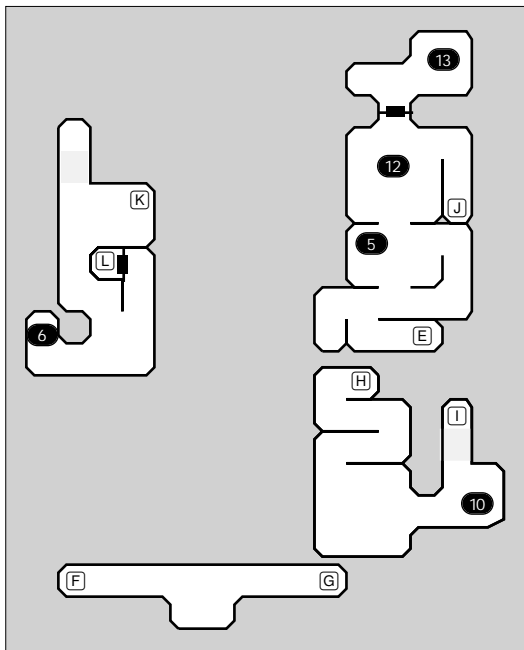

Level 4

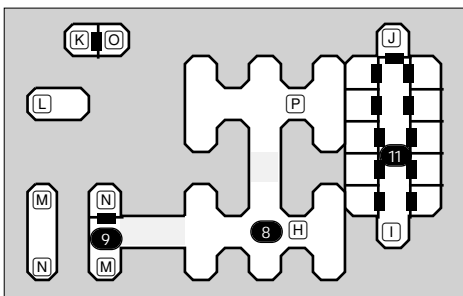

Level 5

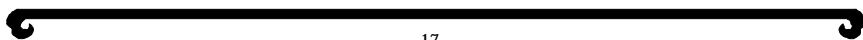
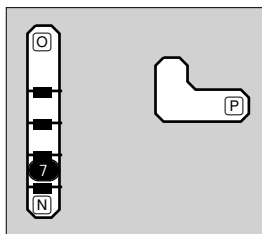



FIEND'S DOMAIN

All is not as it seems in this dungeon. Do not trust the Fiend.

Whatever the Fiend says, it is only in his own interest. The Ring of Shal and the Golden Orb are hidden here. It's possible to avoid the buzzsaws (2), but not easy. Avoid the shortcut (3). It looks attractive, but is full of sleep fields. The chests found in this dungeon are usually empty, but they can be of aid because they explode. Use them against the Cyclops, for example. Some passageways may seem impossible to cross.

Pay attention to your surroundings. Keep an eye out for illusionary walls. The shooter traps (9) won't harm you if you just keep walking.

(The true identity of the Fiend is not hard to figure out — it is Shal.)

English

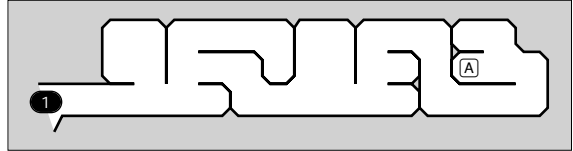

Level 1

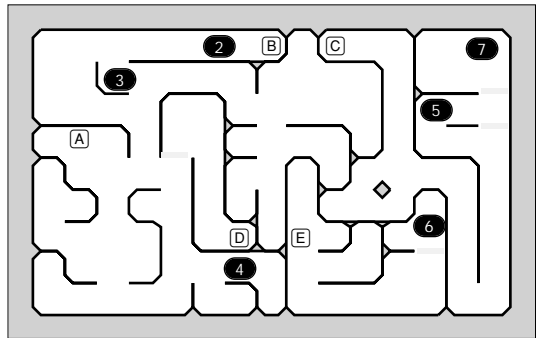

Level 2

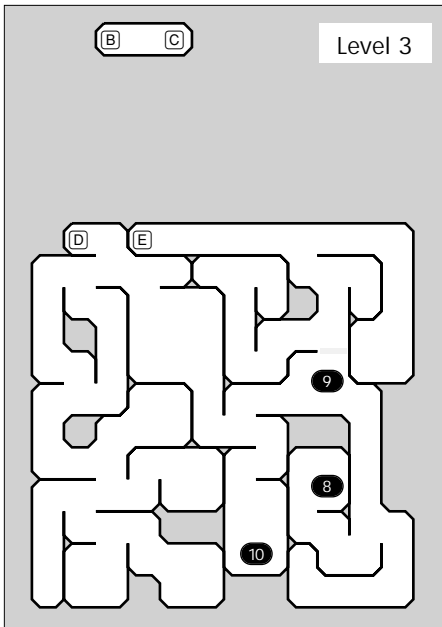

Fiend's Domain

- 1) Entrance
- 2) Buzzsaw hallway
- 3) Shortcut (dangerous)
- 4) Exploding chests
- 5) Impassable hallway
- 6) Ring of Shal (under debris)
- 7) Fiend's room
- 8) Gazers
- 9) Shooter traps
- 10) Golden Orb
-  Illusionary wall





MAGIC ORBS

You must obtain four Magic Orbs during the game to get the Silver Seed and save Serpent Isle from destruction.

The Orbs have different colours: red, blue, purple and gold. Each dungeon contains one Orb. The Purple Orb is in the Maze. Aram-Dol's lair contains the Blue Orb. You can find the Red Orb in the Abandoned Outpost of the keep, and the Golden Orb in the Fiend's Domain.

THE SILVER SEED

Get all other magic items first. Use the Orbs to unlock the vault.

You need the four Magic Orbs to get the Silver Seed. Find the vault with the Silver Seed under the Keep (down the lab stairs under the wine cask (I) to (13); the wine cask can be moved by pressing the button behind a candlestick at (J)). Put an Orb on each of the pedestals to unlock the vault. Get the Silver Seed. Fight the Dark Monks when they appear. Get the keys off of the bodies of the Dark Monks. Open the locked door across from the Silver Seed and enter the tunnels leading up from the Order Keep. You arrive in a glade. The monk Karnax appears, to help you. Plant the Silver Seed here and watch the Tree of Balance grow. You can leave via the tunnel leading back to the Order Keep.

OTHER MAGIC ITEMS

Key Ring. Isstanar gives you the Key Ring after you talk to him.

Gloves of Karas the Quick and Erinon's Axe. These are very powerful and it won't be easy to get them. You can obtain them in Aram-Dol's treasure room.

Loriel's Gift — The Belt of Strength. This belt can be found at (12) in the Abandoned Outpost.

Helm of Light. The helm is on the dead architect, in the fourth sector of the Maze.

Ring of Shal. The ring is hidden under a pile of debris, at (6) in the Fiend's Domain.

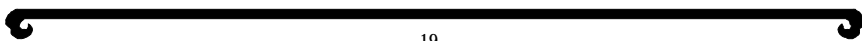



Magic Items

Here is a short description of all new magic items in *The Silver Seed*. You can acquire these powerful aids by solving the quests. Refer to the solution if you need help finding them.

Key Ring. Every key you add to your inventory while you have this key ring automatically attaches itself to the key ring. (You can also Use a key on the key ring to add it to the ring.) The key disappears, and there is no more searching for the appropriate key in your inventory. Don't lose it; it will be gone forever, along with any keys that are on it. See Hot Keys (below) for how to Use the key ring.

Helm of Light. This helm serves as a permanent light source — you don't have to carry a lit torch while wearing it. Your hands will be free to carry weapons and shields. It has a Defense Value of 4, and keeps you warm like a fur helm. Wear it as you would wear a normal helm.

Belt of Strength. This belt increases your strength by ten points. Wear it as your regular belt. (Make sure that the belt slot is open before you try to put it on.)

Ring of Shal. This ring supplies you with unlimited reagents to cast spells. Slip it on your finger like a normal ring, and you no longer need to collect reagents. It cannot help anyone else.

Gloves of Karas the Quick. These gloves increase your dexterity by ten points. They have the same Defense Value as magic gauntlets (3). Make sure that you aren't wearing any other gloves or gauntlets before you try to put them on.

Erinon's Axe. This powerful weapon increases your combat ability by ten points. Its Damage is 20 and it has a Reach of 4. (It can not be thrown.) The axe automatically equips to your right hand if you are not holding anything else in that hand.

Orbs. The orbs have no use beyond the Silver Seed quest.

Silver Seed. You must plant the Silver Seed at a hallowed site. It is the seed for the magic Tree of Balance. This tree can save Serpent Isle from destruction.

Hot Keys

The Silver Seed provides you with several new *hot keys*, usable both in this module and while playing the rest of *Serpent Isle*. Several recurring procedures needed to play your game are now a matter of a single keystroke. Note that *Serpent Isle* keystrokes and all other functions remain the same.

Checking the Time. If you have a pocket watch, you can always find out what time it is by pressing **[W]** on your keyboard.

Feeding Yourself and Your Party. To feed yourself and/or your party members, press **[F]** and click on the hungry person with your mouse. This function will feed that party member until he or she is full. (This assumes that someone in your party is currently carrying food. **[F]** doesn't create food, it just quickly distributes any food that is available.)

Using Keys. If you have the magic key ring, you don't have to search through your keys any more. Press **[K]** and cross-hairs appear. Click the cross-hairs on a locked item and — if you have the right key — the item opens. (Once you add a key to this ring, you can not remove it again, but don't worry; there will be no reason to.) Magically locked doors still require a spell.

Picking Locks. If you have a set of lock picks in your inventory, press **[P]** anytime you want to attempt to pick a lock.

